

**P**atented product  
专利产品

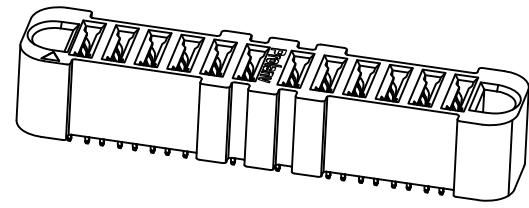
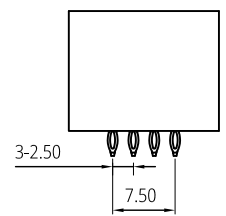
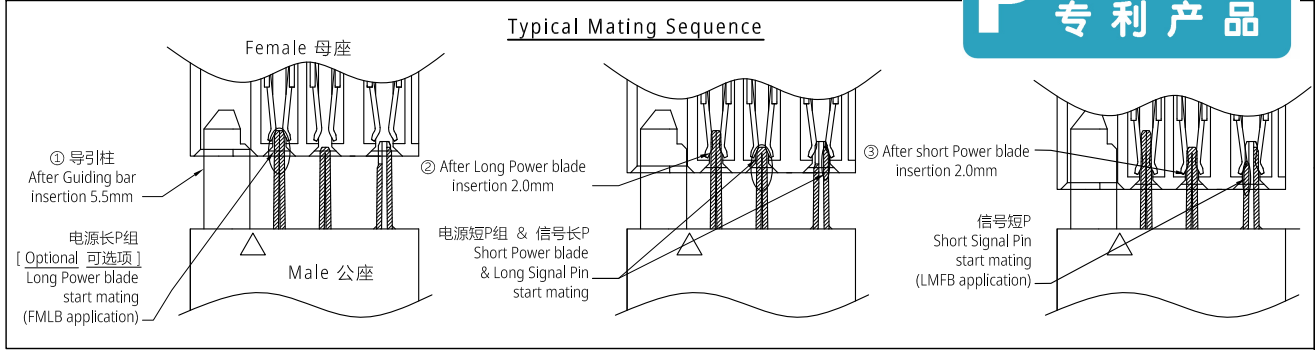
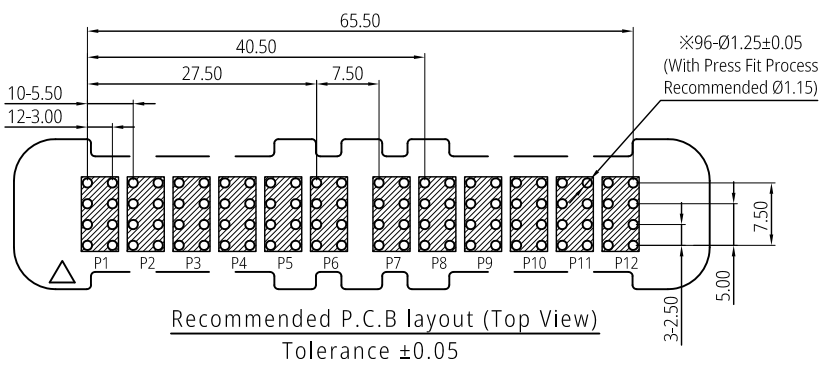
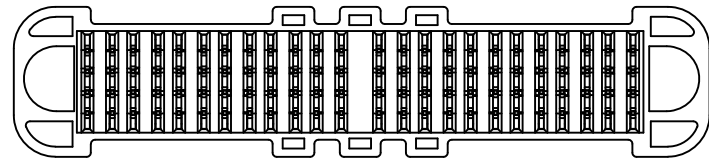
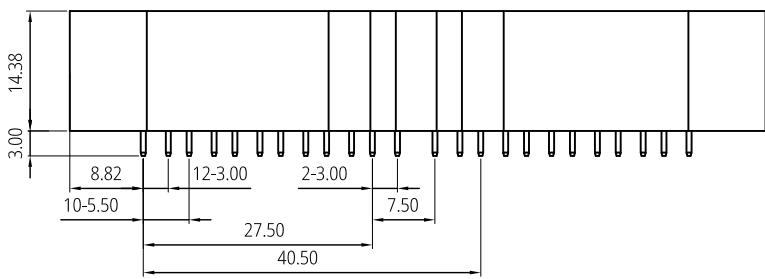
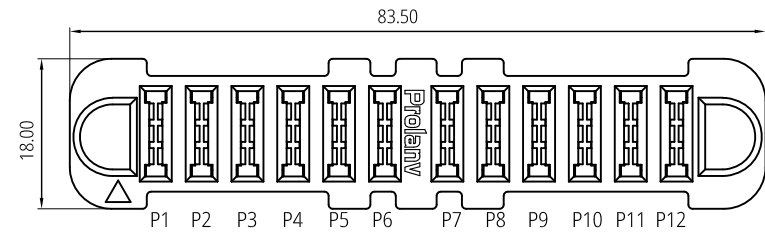

3D View

- Notes:
- Material Specification:
    - Housing: High Temperature Thermoplastic. UL94 V-0, Black;
    - Contact: High Conductivity Copper Alloy;
  - Plating Specification:
    - Contact: Gold plating on Contact area, Matte Tin 80 $\mu$ " min. on Tails, and 50 $\mu$ " min. Nickel overall;
  - Electrical performance:
    - Voltage Rating: 250v DC/power blade;
    - Current Rating: 60A (per pair power blade).
    - LLCR:
      - initial 0.6m $\Omega$  max., finished 1.0m $\Omega$  maximum change.(per pair power blade).
    - Dielectric Withstanding Voltage:
      - 1500v DC rms/power blade.
    - Insulation Resistance:
      - 5000 M $\Omega$  min/Power blade.
  - Mechanical Performance:
    - Insertion Force: 19.6N (2.0kgf) max./Per Pair;
    - Withdrawal Force: 4.5~11N (0.4~1.2kgf)/Per Pair;
    - Durability Life: 10,000 cycles. max.
  - IR Reflow:
    - The peak temperature on board shall be maintained for 10 seconds at 260 $\pm$ 5 $^{\circ}$ c.
  - Operating Temperature rang: -40~125 $^{\circ}$ c.
  - All parts RoHS and Reach compliant.
  - ※ See SPS-PDC-06 for Terminal details.

THIS DRAWING AND SPECIFICATION ARE THE PROPERTY OF Prolanv AND SHALL NOT BE COPIED OR USED WITHOUT Prolanv PERMISSION	GENERAL TOLERANCES UNLESS SPECIFIED		PART NO. PDC3010F0001	<b>Prolanv</b> <sup>®</sup>			
	X $\pm$ 0.30	X $^{\circ}$ $\pm$ 3 $^{\circ}$					APPROVED BY Mike
	XX $\pm$ 0.20	.X $^{\circ}$ $\pm$ 2 $^{\circ}$	CHECKED BY Henry	DWG NO. PDC30-10			
	XXX $\pm$ 0.05	.XX $^{\circ}$ $\pm$ 1 $^{\circ}$					DRAWN BY Poplar
	SIZE A4	UNITS mm[only]					

1 2 3 4 5 6 7 8

F

E

D

C

B

A

F

E

D

C

B

A

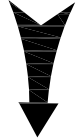
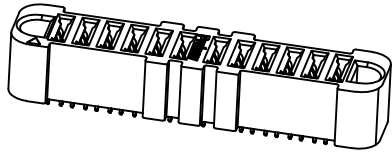

15 Pcs/Tray

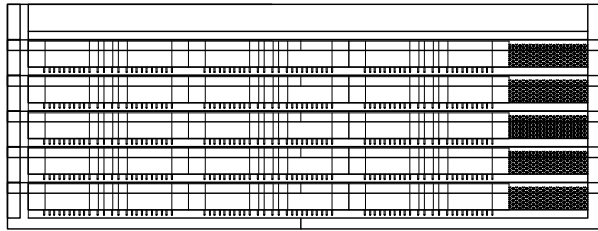

Total: 2x5 Layers

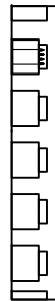
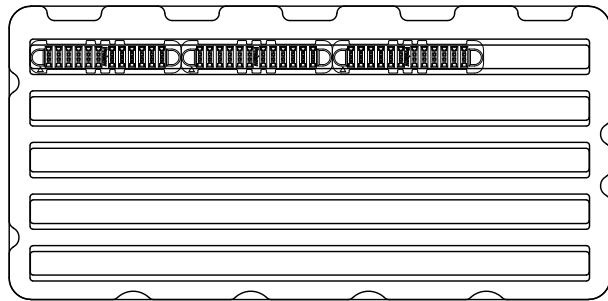

PE Film

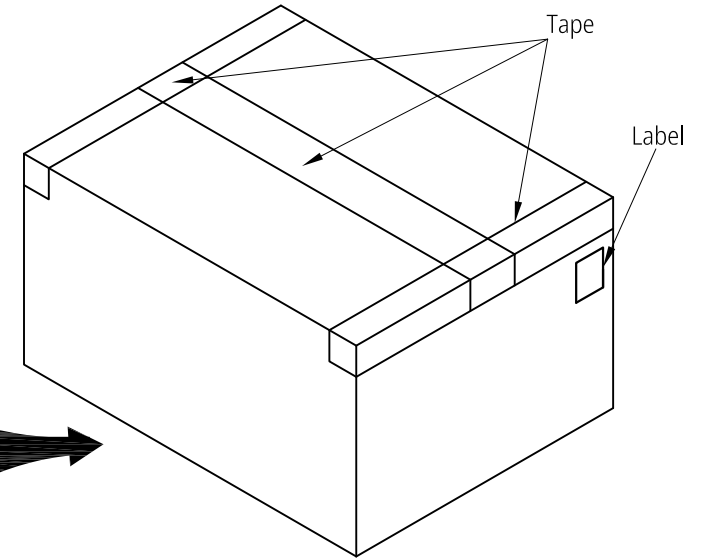
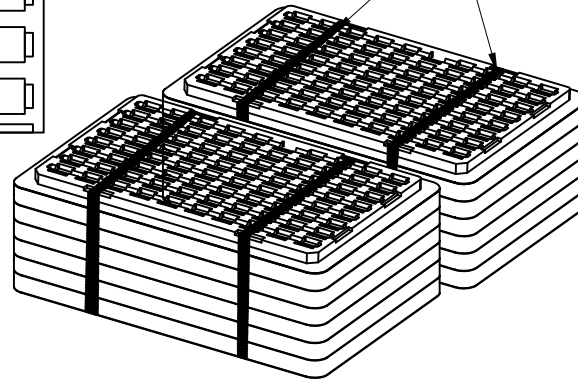

Notes:

1. Q'ty: 15 Pcs/Tray, 2x5 Layers=150 Pcs/Carton.
2. Tray Pallet size: 332\*162mm.
3. Carton size: 350\*350\*155mm.

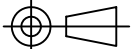
THIS DRAWING AND SPECIFICATION ARE THE PROPERTY OF Prolanv and SHALL NOT BE COPIED OR USED WITHOUT Prolanv PERMISSION	GENERAL TOLERANCES UNLESS SPECIFIED		PART NO.	<b>Prolanv</b> <sup>®</sup>			
	X ± 0.30	X° ± 3°	PDC3010F0001				
	XX ± 0.20	XX° ± 2°	APPROVED BY	TITLE			
	XXX ± 0.05	XXX° ± 1°	Kysin	EN60A series   Power Female. 12 Pairs Pin, Straight Type, Packaging			
	CUSTOMER DRAWING		CHECKED BY	DWG NO.			
			Harry	P-PDC30-10			
SIZE	UNITS	DRAWN BY			SHEET	SCALE	REV
A4	mm[only]	Lucie			2 / 2	N/A	A2

1 2 3 4 5 6 7 8