

Patented product
专利产品

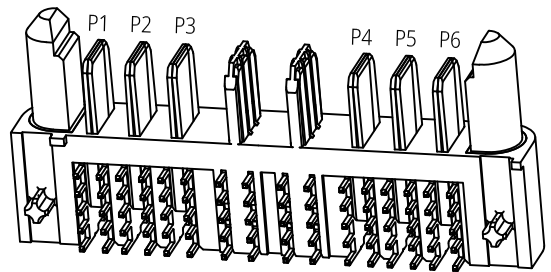
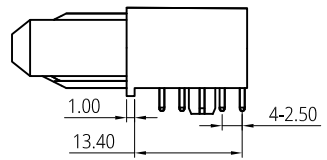
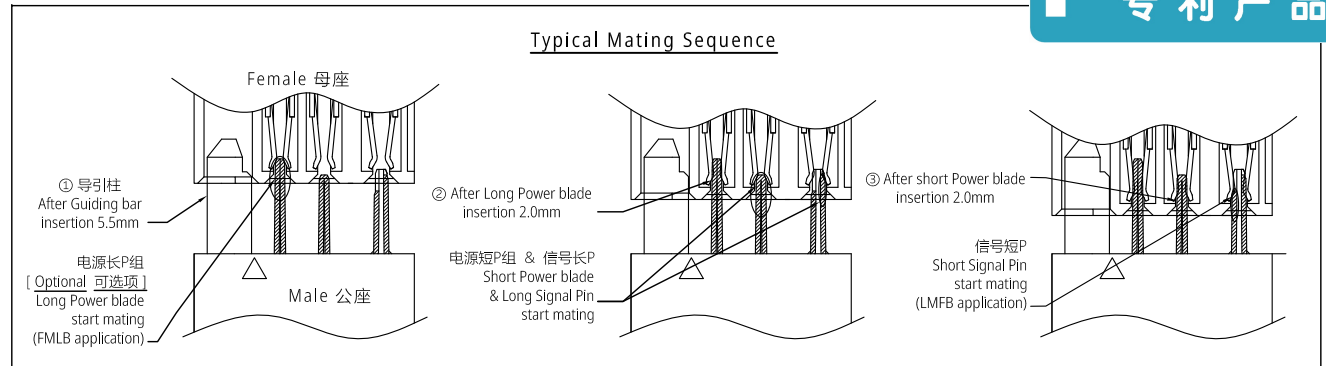
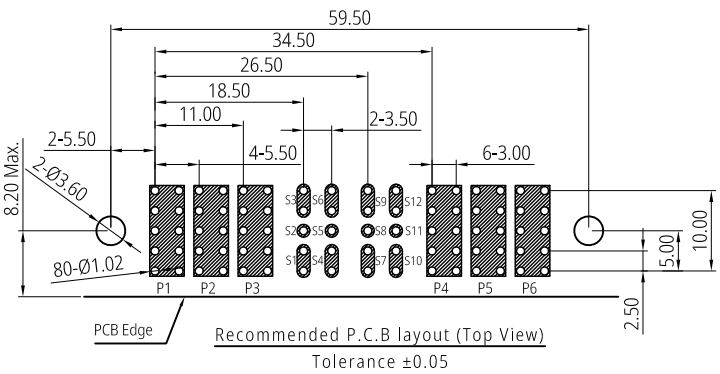
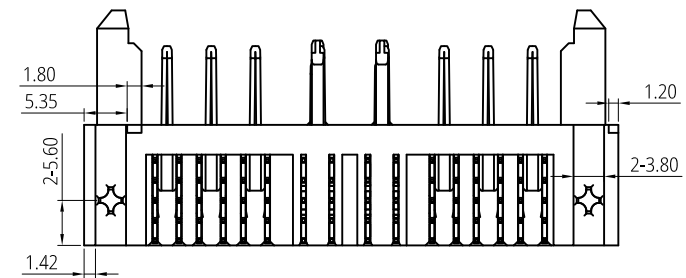
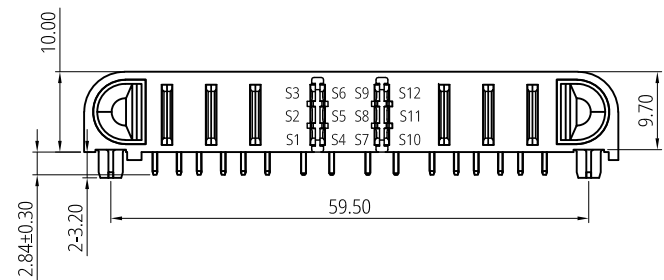
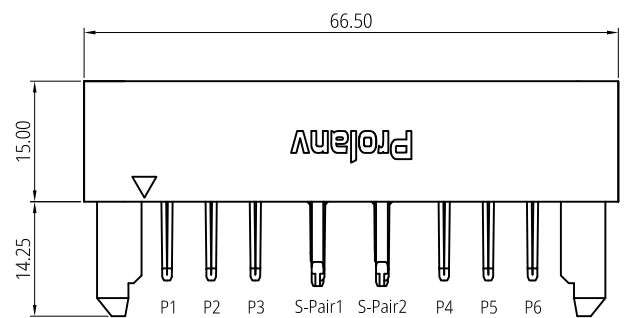

Part Number: PDC1710F0003
Optional Long Power blade
可选项 长电源P组数 | Pairs
Code: 1~9 & A~C
Long Power blade
长电源P组 | 起始位
Start location code: 1~9 & A~C
Long Power blade
长电源P组 | 终止位
End location code: 1~9 & A~C

THIS DRAWING AND SPECIFICATION ARE THE PROPERTY OF Prolanv AND SHALL NOT BE COPIED OR USED WITHOUT Prolanv PERMISSION

GENERAL TOLERANCES UNLESS SPECIFIED	PART NO.
.X ± 0.30	PDC1710F0003
.XX ± 0.20	APPROVED BY
.XXX ± 0.05	Henry
SIZE	CHECKED BY
A4	Poplar
UNITS	DRAWN BY
mm[only]	Kaylee

- Notes:
- Material Specification:
 - Housing: High Temperature Thermoplastic. UL94 V-0, Black;
 - Contact: High Conductivity Copper Alloy;
 - Metal Rod: Alloy.
 - Plating Specification:
 - Contact: Gold plating on Contact area, Matte Tin 80µ" min. on Tails, and 50µ" min. Nickel overall;
 - Metal Rod: Nickel overall.
 - Electrical performance:
 - Voltage Rating: 250v DC/power blade, 120v DC/signal pin;
 - Current Rating: 60A (per pair power blade).
 - LLCR:
 - initial 0.6mΩ max., finished 1.0mΩ maximum change.(per pair power blade);
 - initial 10mΩ max., finished 20mΩ maximum change.(per signal pin).
 - Dielectric Withstanding Voltage:
 - 1500v DC rms/power blade; 500v DC rms/signal pin.
 - Insulation Resistance:
 - 5000 MΩ min/Power blade; 500 MΩ min/Signal Pin.
 - Mechanical Performance:
 - Insertion Force: 19.6N (2.0kgf) max./Per Pair;
 - Withdrawal Force: 4.5~11N (0.4~1.2kgf)/Per Pair;
 - Durability Life: 10,000 cycles. max.
 - IR Reflow:
 - The peak temperature on board shall be maintained for 10 seconds at 260±5°C.
 - Operating Temperature rang: -40~125°C.
 - All parts RoHS and Reach compliant.

CUSTOMER DRAWING	PART NO.
	PDC1710F0003
	APPROVED BY
	Henry
	CHECKED BY
	Poplar
	DRAWN BY
	Kaylee

Prolanv®		
TITLE	DWG NO.	REV
EN60A series Power Male. 6PW+12S, R/A DIP Type	PDC17-03	A0
	SHEET	SCALE
	1 / 2	1:1

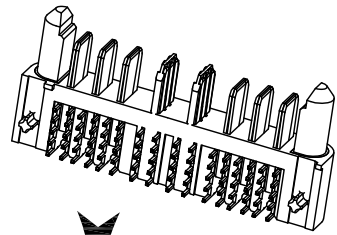

20pcs/Tray

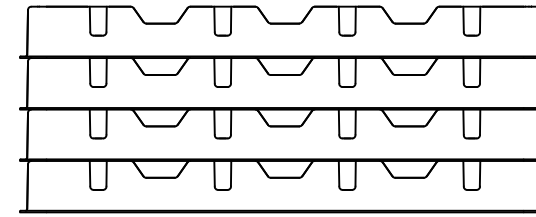

Total 2*4 Layers

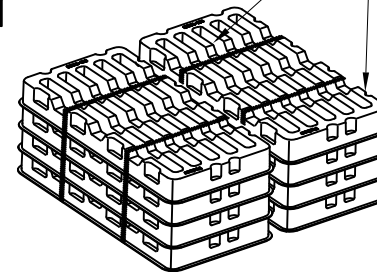
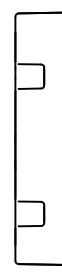
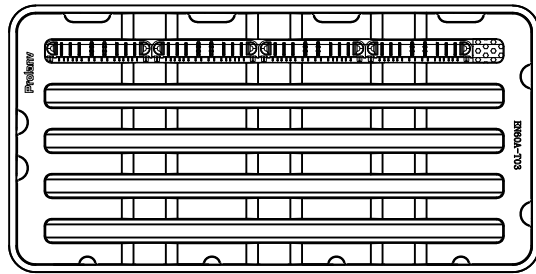

PE Film

Tape

Label

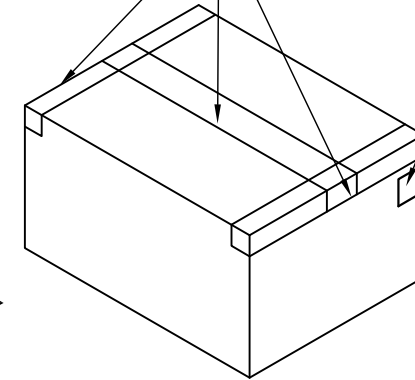

Notes:

1. Q'ty: 20Pcs/Tray, 2x4 Layers=160 Pcs/Carton.
2. Tray Pallet size: 332*162*17mm.
3. Carton size: 350*350*155mm.

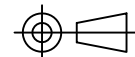
THIS DRAWING AND SPECIFICATION ARE THE PROPERTY OF Prolanv AND SHALL NOT BE COPIED OR USED WITHOUT Prolanv PERMISSION	GENERAL TOLERANCES UNLESS SPECIFIED		PART NO.	Prolanv [®]		
	X ± 0.20	X° ± 3°	PDC1710F0003			
	.XX ± 0.10	.X° ± 2°	APPROVED BY	TITLE EN60A series Power Male 6PW+12S, R/A DIP Type, Packaging		
	.XXX ± 0.05	.XX° ± 1°	Henry			
	CUSTOMER DRAWING		CHECKED BY	DWG NO. P-PDC17-03		
			Poplar			
SIZE	UNITS	DRAWN BY				
A4	mm[only]	Kaylee				SHEET
			2 / 2	NA	A0	